

推奨基板寸法  
(t = 1.6)

|    |    |    |                   |    |
|----|----|----|-------------------|----|
| 31 | 28 | 34 | 55935-15**        | 15 |
| 29 | 26 | 32 | 55935-14**        | 14 |
| 27 | 24 | 30 | 55935-13**        | 13 |
| 25 | 22 | 28 | 55935-12**        | 12 |
| 23 | 20 | 26 | 55935-11**        | 11 |
| 21 | 18 | 24 | 55935-10**        | 10 |
| 19 | 16 | 22 | 55935-09**        | 9  |
| 17 | 14 | 20 | 55935-08**        | 8  |
| 15 | 12 | 18 | 55935-07**        | 7  |
| 13 | 10 | 16 | 55935-06**        | 6  |
| 11 | 8  | 14 | 55935-05**        | 5  |
| 9  | 6  | 12 | 55935-04**        | 4  |
| 7  | 4  | 10 | 55935-03**        | 3  |
| 5  | 2  | 8  | 55935-02**        | 2  |
| C  | B  | A  | MATERIAL NO. CKT. |    |

MODEL NO. : 55935-\*\*\*\*

3~15極 側面図

MATERIAL  
ピン: 黄銅, ニッケル下地錫メッキ  
ハウジング: PBT

|  |                                       |  |                             |  |  |                        |
|--|---------------------------------------|--|-----------------------------|--|--|------------------------|
| REVISED<br>EC NO: J2014-0331<br>DRWN: YAJI MA01 2013/08/22<br>CHKD: KASAKAWA 2013/08/23<br>APPR: NUKITA 2013/08/26 | GENERAL TOLERANCES (UNLESS SPECIFIED) |  | DIMENSION STYLE<br>MM ONLY  | SCALE<br>---   | DESIGN UNITS<br>METRIC   | THIRD ANGLE PROJECTION |
|  | 10 UNDER                              | ±0.20  | DRAWN BY<br>T. NIITSU       | DATE<br>'02/05/15  | TITLE<br>2.0 W/B SINGLE CONN.<br>PLUG HOUSING ASS'Y R/A<br>-LEAD FREE- |                        |
|  | 10 OVER 30 UNDER                      | ±0.25  | CHECKED BY<br>K. ASAKAWA    | DATE<br>'03/06/12  |  |                        |
|  | 30 OVER                               | ±0.30  | APPROVED BY<br>T. YAMAGUCHI | DATE<br>'03/06/12  |  |                        |
| REV  | DESCRIPTION                           | ANGULAR ±3 °   | MATERIAL NO.                | SEE CHART  | DOCUMENT NO.<br>SD-55935-005   | SHEET NO.<br>1 OF 2    |
|  |                                       | DRAFT WHERE APPLICABLE<br>MUST REMAIN<br>WITHIN DIMENSIONS | SIZE<br>A3                  | THIS DRAWING CONTAINS INFORMATION THAT IS PROPRIETARY TO MOLEX<br>INCORPORATED AND SHOULD NOT BE USED WITHOUT WRITTEN PERMISSION |  |                        |

10 9 8 7 6 5 4 3 2 1

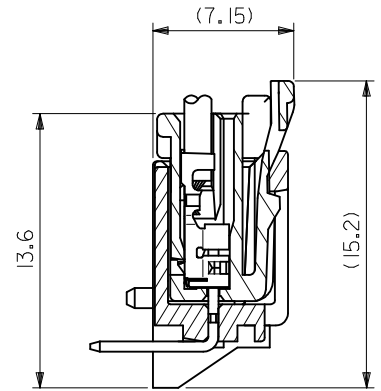
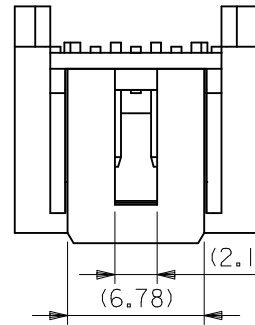
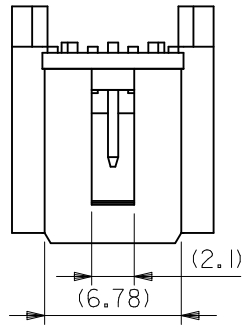
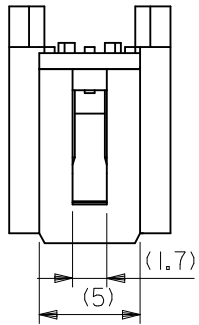

嵌合断面図

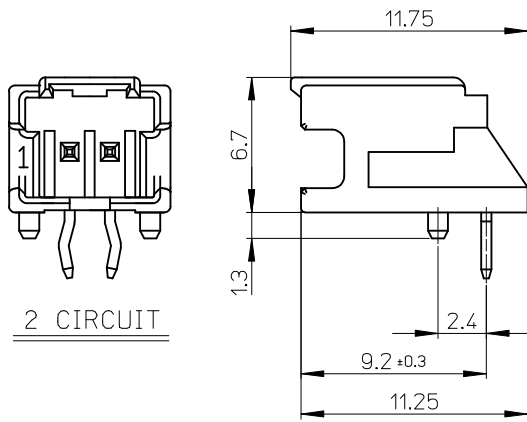

2 CIRCUIT

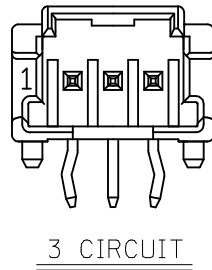

3 CIRCUIT

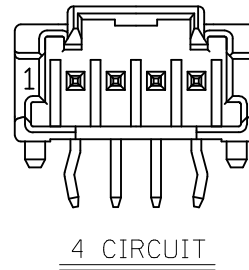

4 CIRCUIT

MODEL NO.: 55935-\*\*\*\*

|  |  |  |                            |                           |   |                              |                           |                     |
|--|--|--|----------------------------|---------------------------|---|------------------------------|---------------------------|---------------------|
| REVISED<br>EC NO: J2014-0331<br>DRWN: YAJI MA01 2013/08/22<br>CHKD: KASAKAWA 2013/08/23<br>APPR: NUKITA 2013/08/26 | GENERAL TOLERANCES<br>(UNLESS SPECIFIED) |  | DIMENSION STYLE<br>MM ONLY |                           | SCALE<br>---  | DESIGN UNITS<br>METRIC       | THIRD ANGLE<br>PROJECTION |                     |
|  | 10 UNDER                                 | ±0.20  | DRAWN BY                   | DATE                      | TITLE   |                              |                           |                     |
|  | 10 OVER 30 UNDER                         | ±0.25  | T. NIITSU                  | '02/05/15                 | 2.0 W/B SINGLE CONN.<br>PLUG HOUSING ASS'Y R/A<br>-LEAD FREE- |                              |                           |                     |
|  | 30 OVER                                  | ±0.30  | K. ASAKAWA                 | '03/06/12                 |   |                              |                           |                     |
| ANGULAR ±3 °<br>DRAFT WHERE APPLICABLE<br>MUST REMAIN<br>WITHIN DIMENSIONS   |  | APPROVED BY<br>T. YAMAGUCHI '03/06/12  |                            | MATERIAL NO.<br>SEE CHART |   | DOCUMENT NO.<br>SD-55935-005 |                           | SHEET NO.<br>2 OF 2 |
| SIZE<br>A3   |  | THIS DRAWING CONTAINS INFORMATION THAT IS PROPRIETARY TO MOLEX<br>INCORPORATED AND SHOULD NOT BE USED WITHOUT WRITTEN PERMISSION |                            |                           |   |                              |                           |                     |

9 8 7 6 5 4 3 2